

Montageanleitung Mounting instructions Instructions de montage

EKU PORTA®





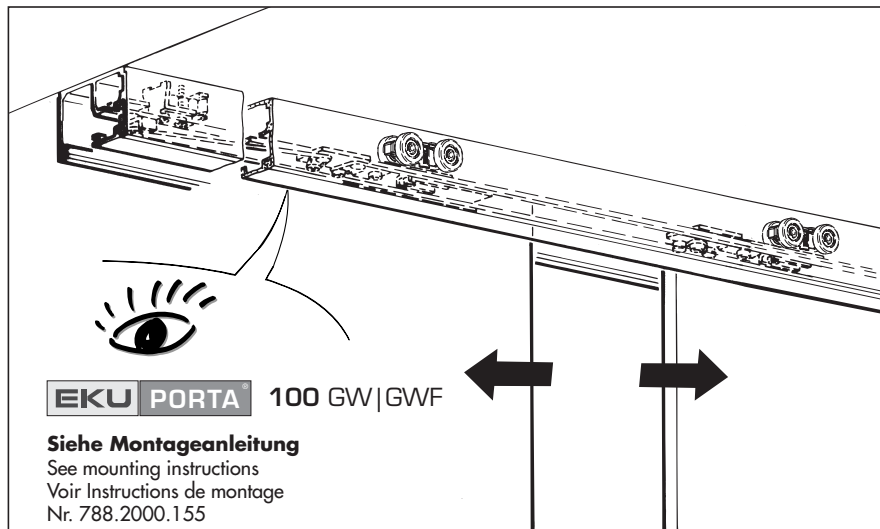

100 GW | GWF Synchro

Anforderungen erfüllt nach

DIN-EN 1527 - 6 2 0 - 0 - 1 3

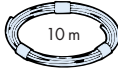

Garnituren / Sets / Garnitures

2 Türen Doors Portes		No. 057.3092.071	
	1x		1x
	1x		2x
	2.70 m		2x

Glaskantenschutzprofil, Kunststoff, glasklar	10 mm/3000 mm	751.0001.300
Protective transparent edge trims, plastic transparent	12 mm/3000 mm	751.0002.300
Profils protecteurs de chant de verre, plastique transparent	12.7 mm/3000 mm	751.0003.300

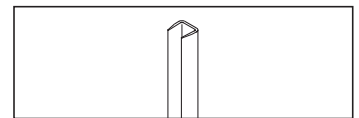

Doppelseitiges Klebeband zu Glaskantenschutzprofil, in Rollen	50 m	751.0004.000
Double-sided adhesive tape for protective edge trims, in coils		
Ruban adhésif doubleface pour profil protecteur de chant de verre		

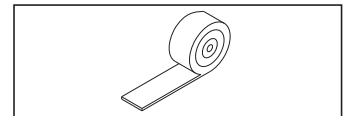

Glaskantenschutzprofil, Kunststoff schwarz, selbstklebend, in Rollen	10 m	057.3080.002
Protectiv edge trims, plastic black, self-adhesive, in coils		
Profils protecteurs de chant de verre, plastique noir, autocollants		

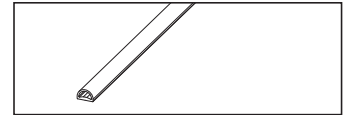

Frässhablone, für mod. GW, GWF (Synchro)	057.3094.001
Milling jig, for mod. GW, GWF (Synchro)	
Gabarit de fraisage, pour mod. GW, GWF (Synchro)	

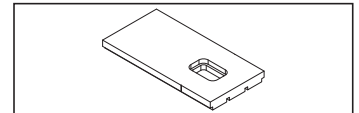

Nutfräser HM (Hartmetall), Durchmesser 10 mm, Länge 70 mm	600.0000.309
Groove cutter HM (hard metal), diameter 10 mm, length 70 mm	
Fraise à rainurer HM (métal dur), diamètre 10 mm, longueur 70 mm	

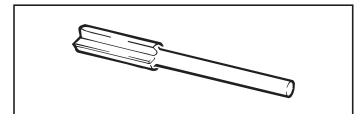

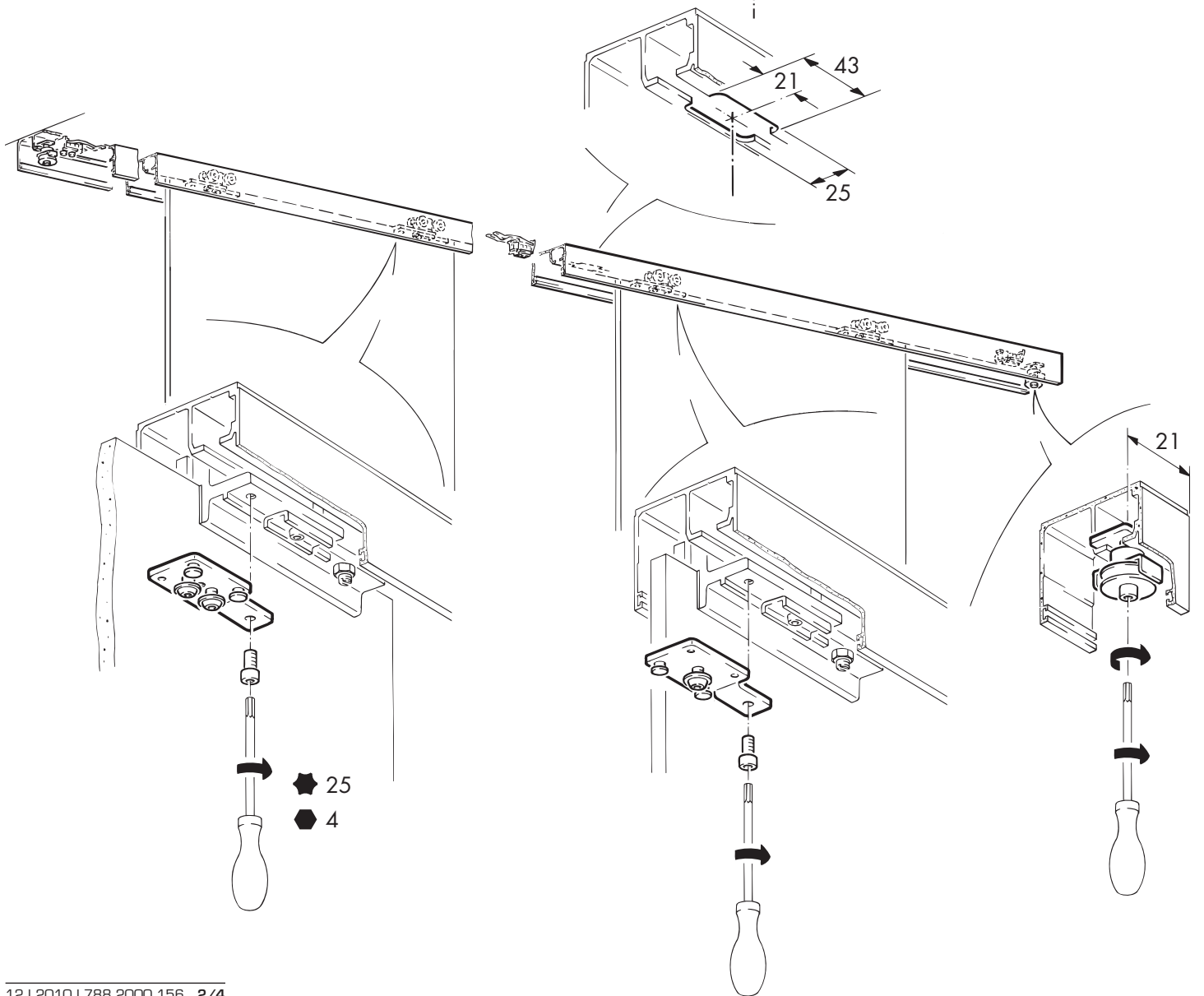
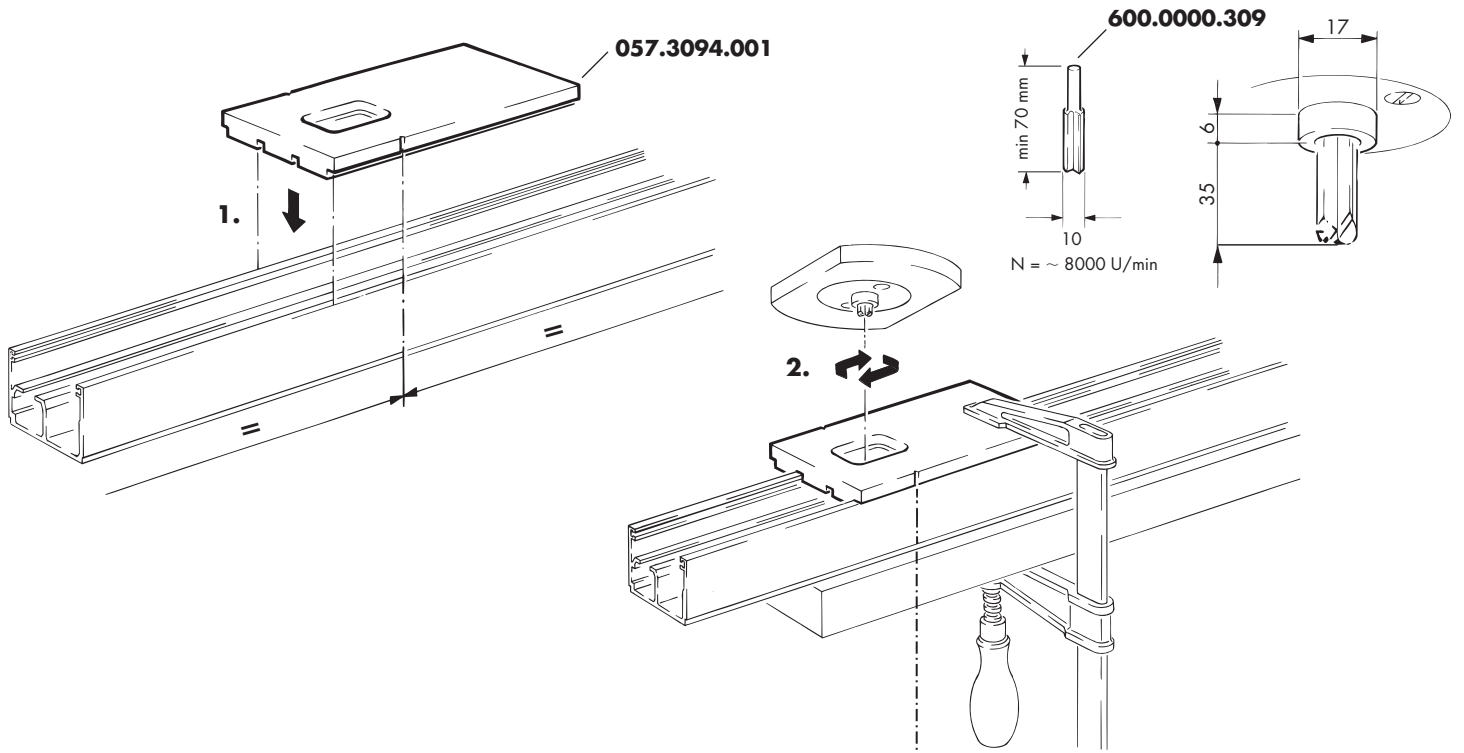

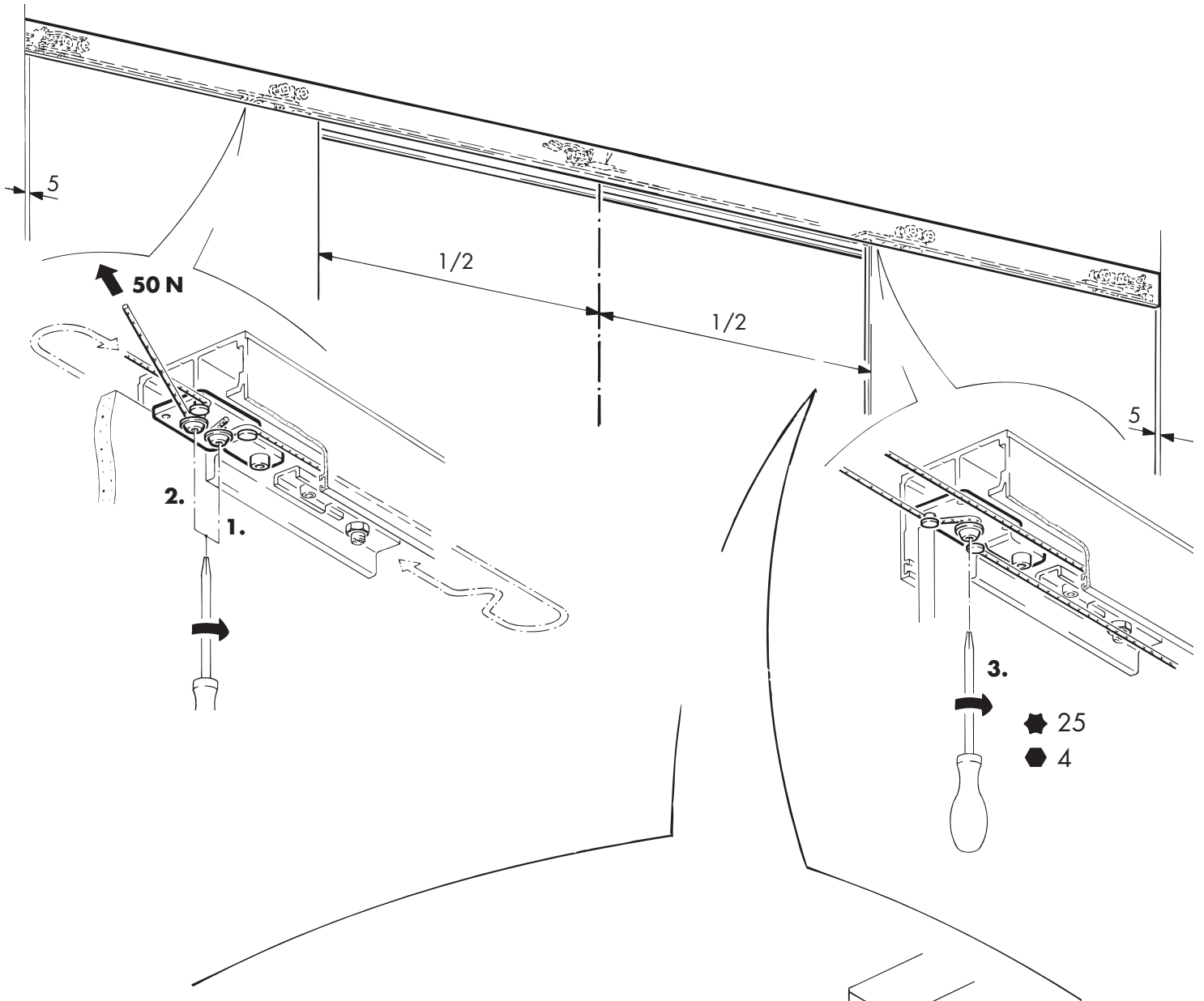

Optional

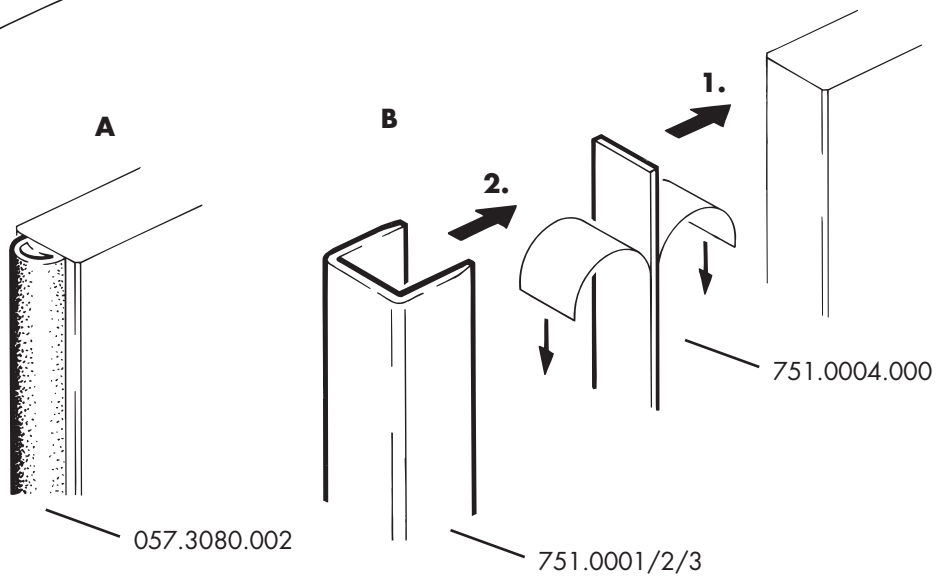

Einbaubeispiele / Mounting examples / Exemples de montage

